



NRENs Data Transport Needs (40Gbps and a simpler L2)

Mauro Campanella
INFN-GARR
Mauro.Campanella@garr.it



Agenda

Explain NRENs needs in data transport area through

- Rationale for 40 Gbps links
- Rationale for simpler L2



Users' total access capacity in Italy

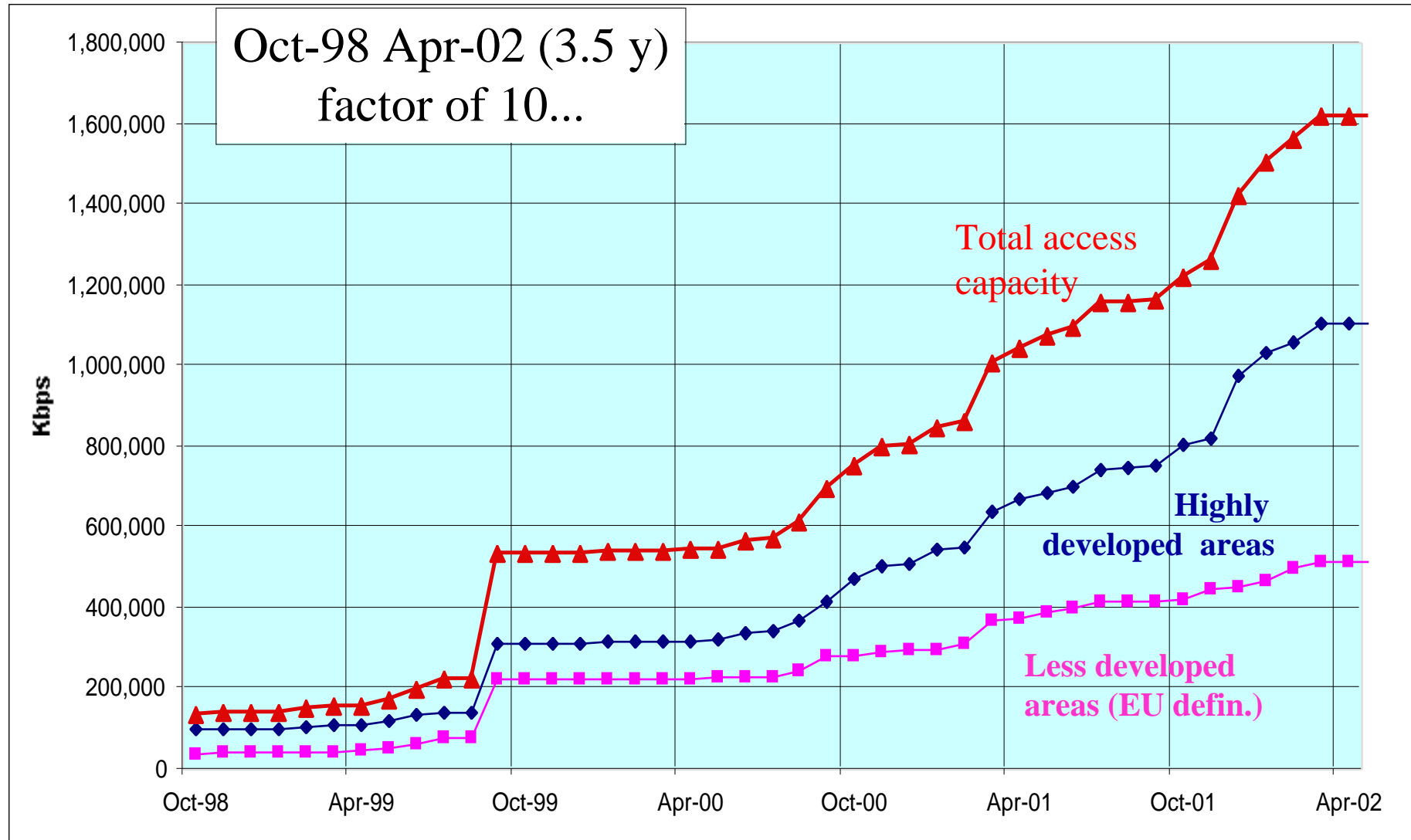



Last 1.5 year of Users' traffic in Italy

- International Commodity (5x) GX (+KPN in June)

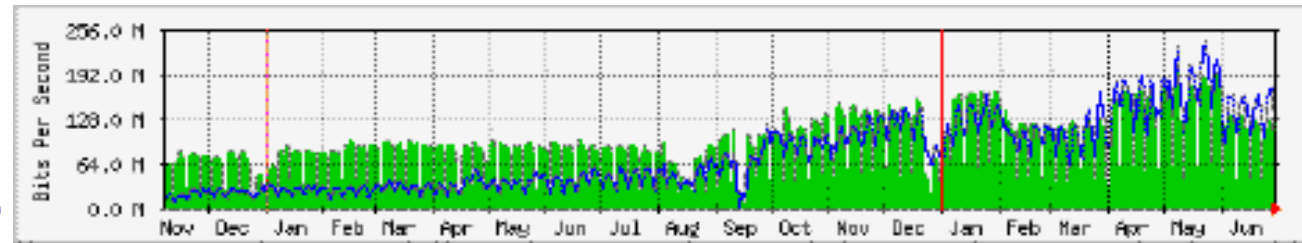

- International Research (5x)

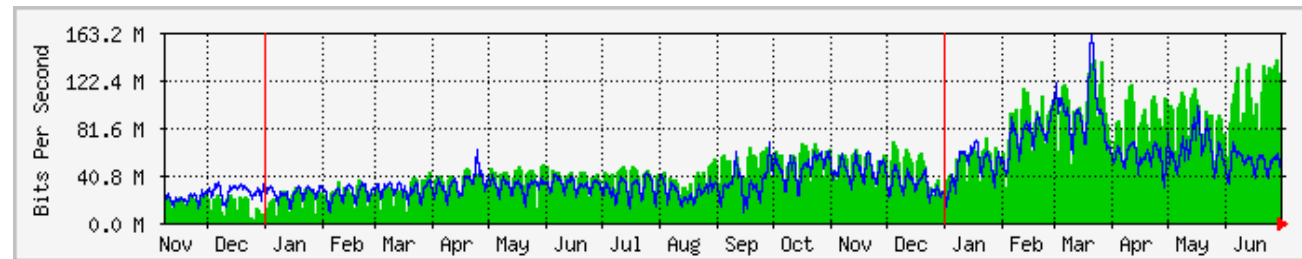

- Local commodity Milan (MIX) (3x)

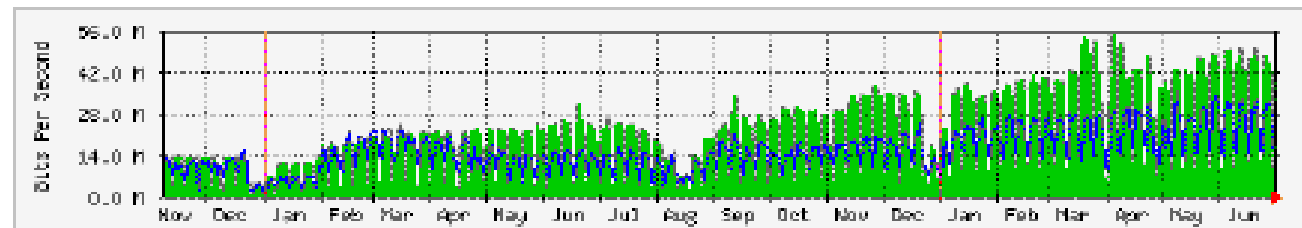

- Local commodity Rome (NAMEX) (5x)

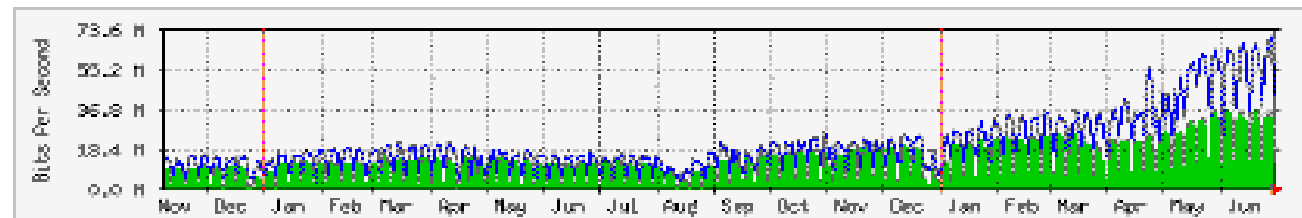



Traffic Patterns are changing

Commodity
(last week)

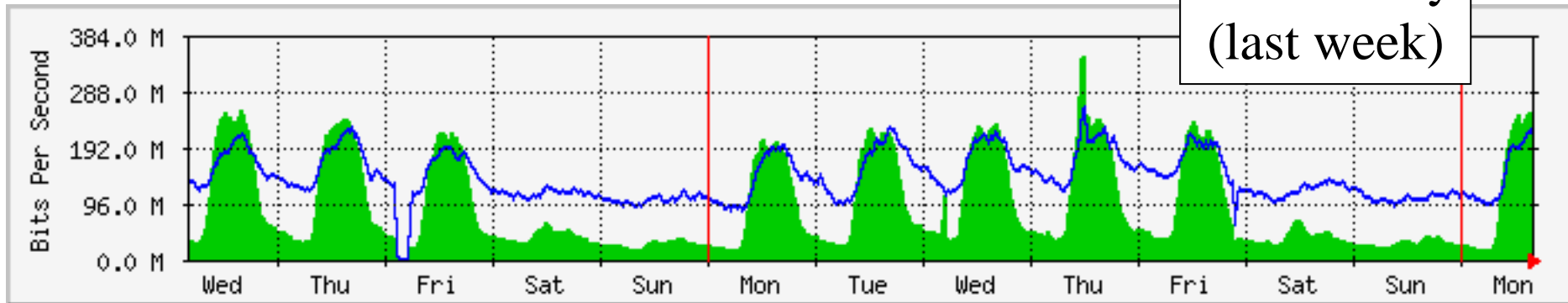

Towards **one** user site (INFN-Pd)
(last month) - bulk data transfer ~75Mb

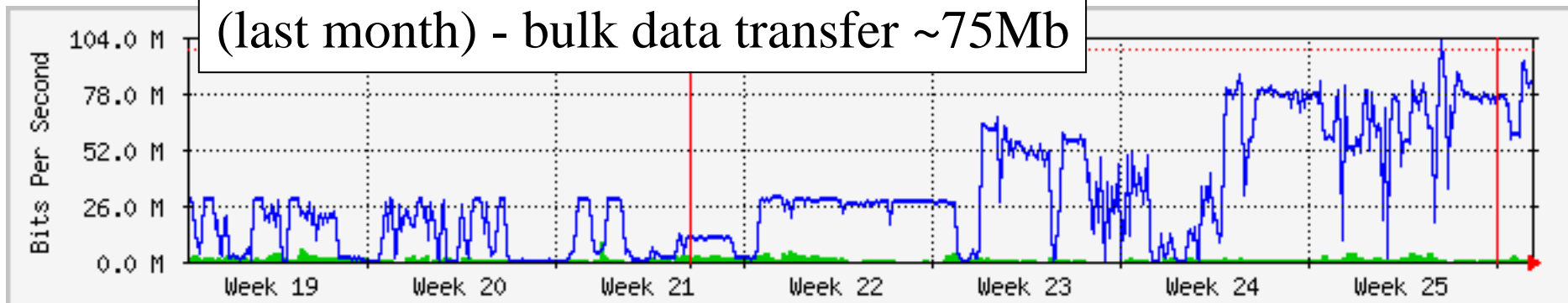

One computer - 100Mb/s - bbftp application
3 parallel transfers -20 streams each



Considerations

Users' capacity requirement is doubling (or more) every 1.5 years.

Users' utilisation grew between 3 and 5 times in 2 years (which means more congested links now)

Core capacity increases in Gigabit quanta

Possibility (at least in Italy) of a quantum leap also in users' access capacity (MANs. privately owned fibers,...)

Peer to Peer is here (in the form of Kazaa, Gnutella,...), that implies a radical change in traffic patterns.



How to face the challenge

Directions:

- keep the network as simple as possible
- build a network than can be upgraded/modified easily
- do not tailor to a particular application/service requirements
- consider the possibility of private-owned fibers

The simplest path looks upgrading the capacity on selected links to 40Gbs, possibly going through an intermediate stage of multiple, parallel 10 Gb/s (Ethernet or SDH or...) and more meshing.

Keep in mind the Canarie example of condo-fibers and capacity/wavelengths abundance as a very cost-effective solution.



Simpler L2

Completely optical packet switching - many years from now ?

A simpler optical transport layer, that tries to suit better IP data transport technology and data (research) network needs.

- fast provisioning
- packet oriented
- scalable at > 40 Gb/s
- simple restoration/protection (may be...)
- minimum requirements for monitoring and fault detection



Meshing

- More complex routing convergence
- Load balancing might be tricky
- Higher human effort

- More apt to grid type of traffic
- Lower capacity requirements to each link
- Easier resiliency



Consider SDH

Pros

- sophisticated fault analysis and in-line information
- standard
- transport of many other L2

Cons

- fixed capacity circuits (nothing between 2.5 and 10 Gb, remains me of PDH ...)
- delicate synchronisation requirements
- complex provisioning system
- long provisioning times
- proprietary management system (no easy IP access to management and monitoring)
- expensive
- 125 μ s granularity (still voice-centric)



from Rodriguez
(Lucent) Globecom 99

Which “IP over WDM”?

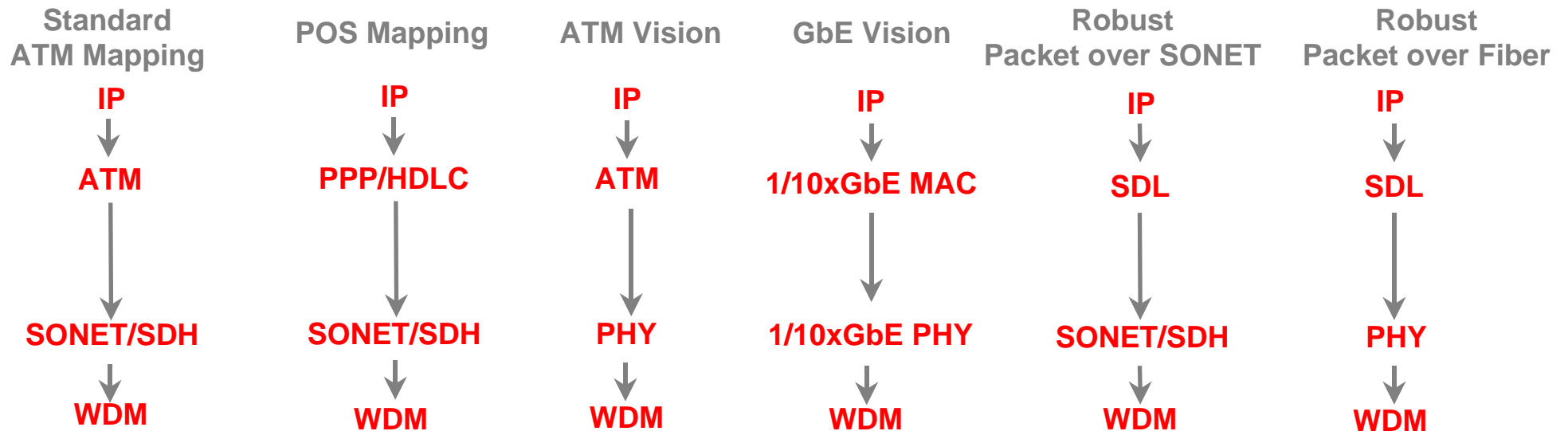

We need the simplest, most economical and flexible solution.

10 GbEthernet on WAN is a good example of how much can be obtained in short time with a “simple”, effective approach (See Switzerland, Poland, Czech republic....)



“Digital Wrappers”

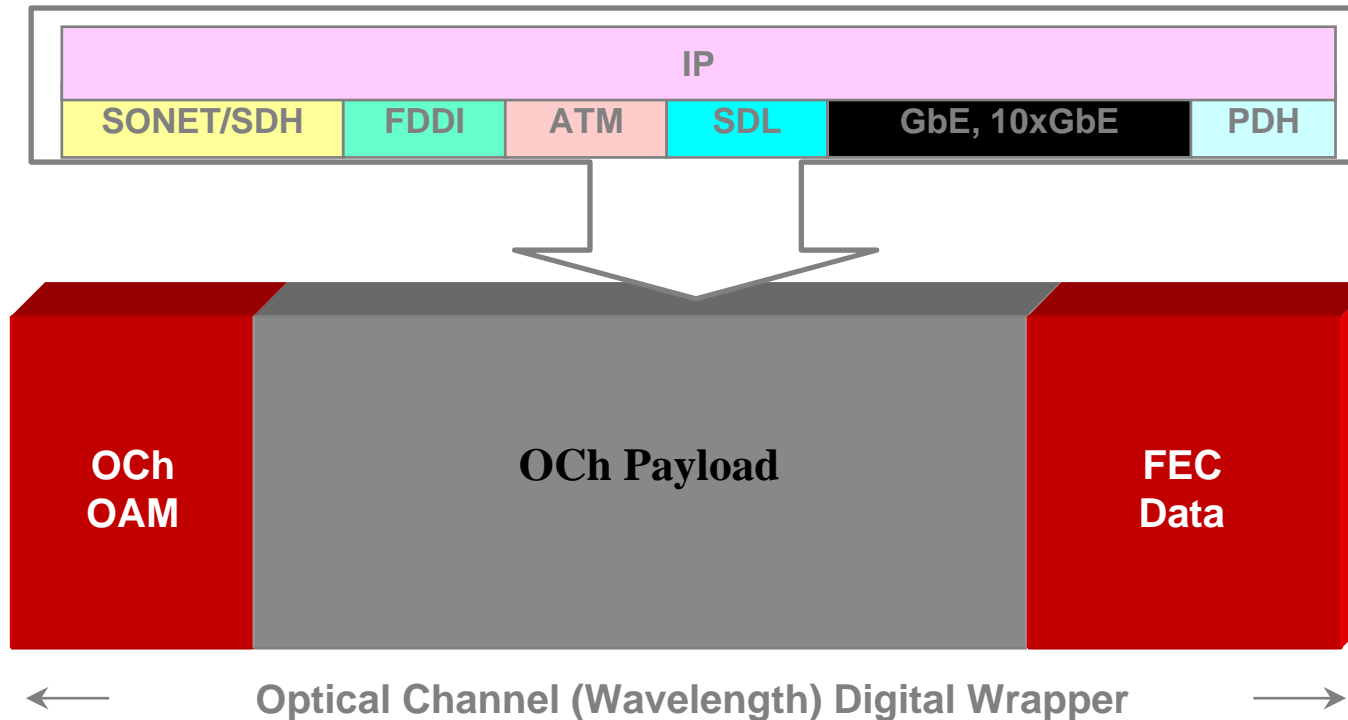

from Rodriguez
(Lucent) Globecom 99

- Wavelength Digital Wrappers are a step toward the original vision of Optical Networking
- Digital Wrappers enable “virtual transparency”
 - Releases the Optical Network from SONET/SDH dependency
 - Allows for end-to-end Optical Transport Networking solutions



Digital Wrappers

- Possibility of TDM like configuration
- No requirements of global synchronisation
- Work done by routers (line can be *terminated* there !)
- resiliency/redundancy done through multiple path.

Various possibilities too:

- at L1 (optically)
- at L2 (trunking, by flow, not packet)
- at L3 (by routing protocols)
- automatic scaling to any particular speed

Just tune wrapper length to IP MTUs
and capacity can be wasted in case for the sake of simplicity