



SWITCH

The Swiss Education & Research Network

Lambda Tunnel A Pilot Optical Service

Felix Kugler <kugler@switch.ch>

SWITCHlan Network 2005

1150 km of dark fiber deployed; 10 year leases from SBB and 20 year IRU from Fibre Lac

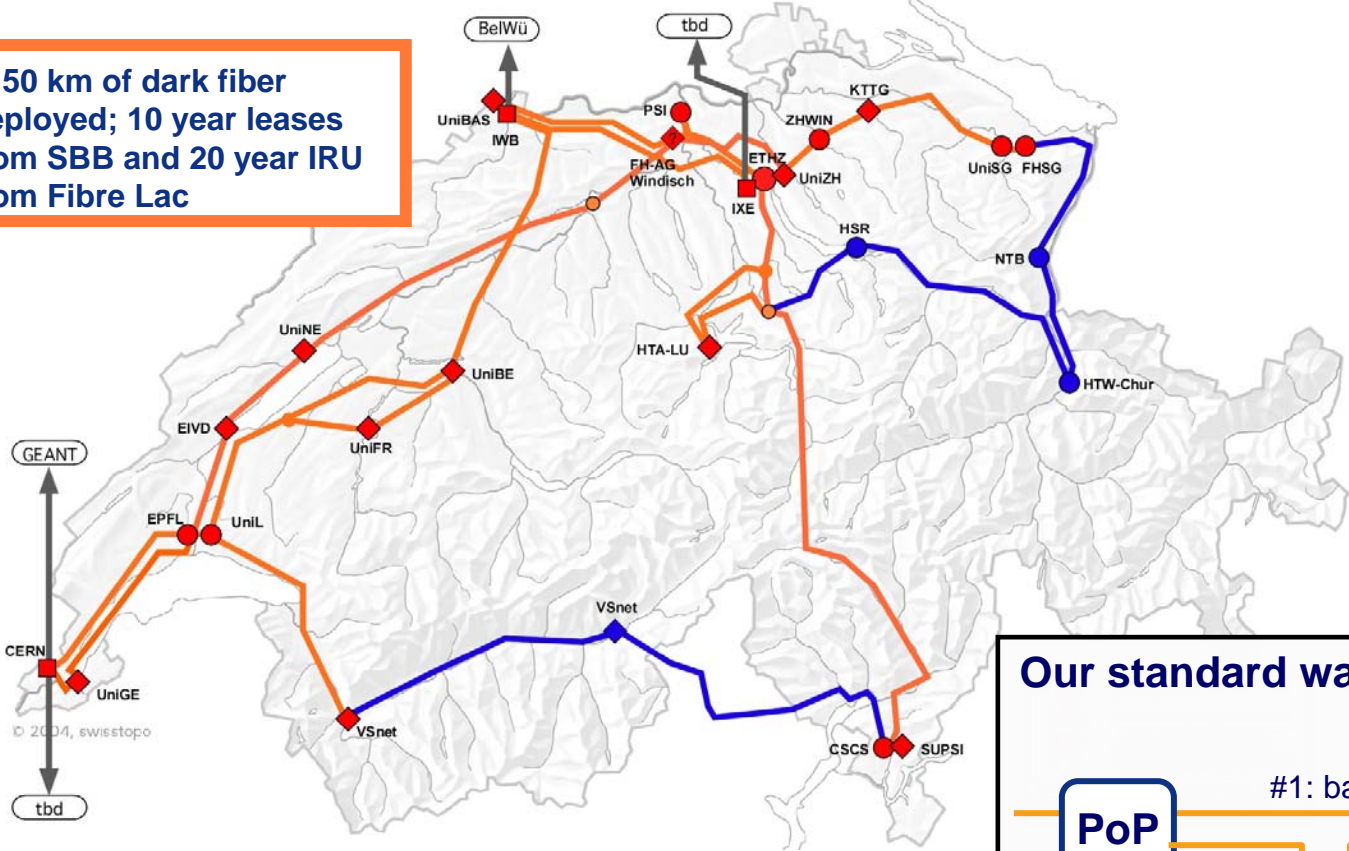

Missing dark fiber links, to be Realized until end of 2005

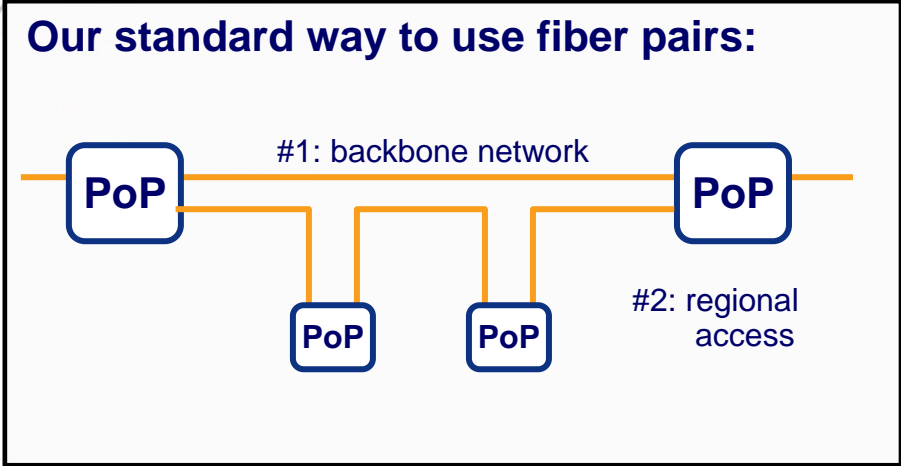

active	IP service	<ul style="list-style-type: none"> • full Internet connectivity (commercial, GEANT/Internet2) • redundant long distance links • access to most services included in fee
	point-to-point links	<ul style="list-style-type: none"> • available in 1 and 10 Gbps speed classes • 1GE or 10GE interfaces (monitored) • not protected!
passive	dark fiber	<ul style="list-style-type: none"> • provisioning of dark fiber where SWITCH has wholesale contracts or owns fibers
	swap or let single fibers	<ul style="list-style-type: none"> • where SWITCHlambda topology & network design allow
	lambda tunnel 	<ul style="list-style-type: none"> • share a fiber's optical spectrum • avoid active components • beware: not available throughout the whole network!

what is it ?

- a fraction of the CWDM spectrum on a lit fiber, assigned to a customer
- the customer can set up and run his own communication links
 - using equipment he is familiar with
 - with local support and “just the right service level”

why is it interesting ?

- bi-directional links using CWDM GBICs widely deployed
- much of the 1500nm range is left !
- dark fiber still expensive on long links

where ?

- add/drop lambda tunnels “anywhere” along existing fiber links
- access points are not restricted to SWITCH PoPs!

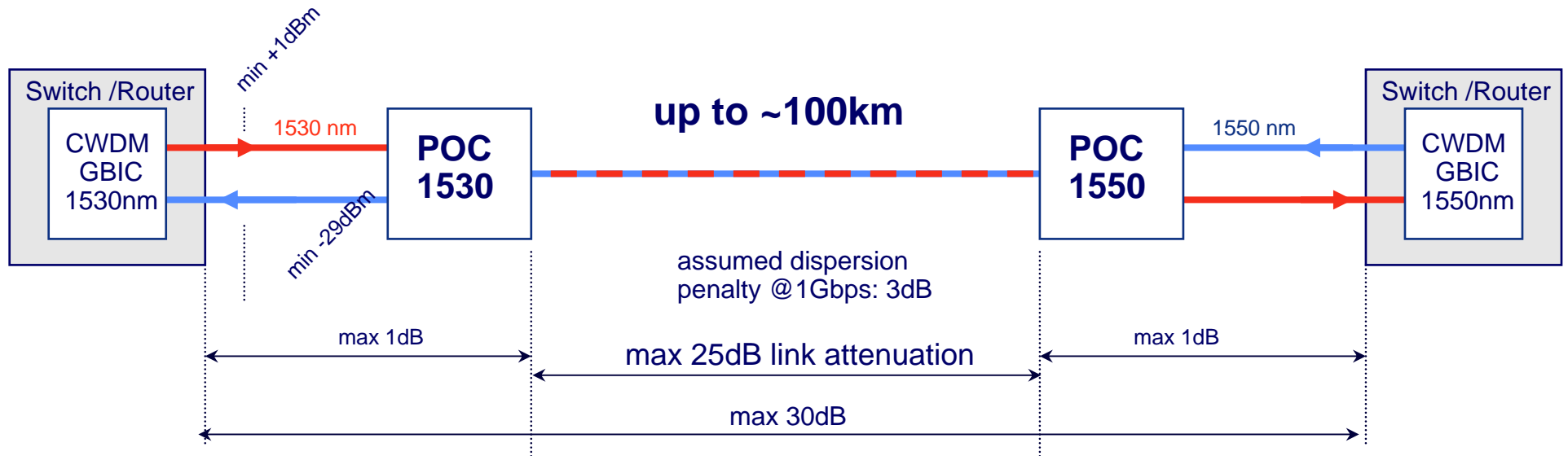

- since 2002, SWITCH has deployed 13 bidirectional links using POCs
- several regional networks have adopted the technology as well
- POC - passive optical couplers:
 - high quality optical filters
 - moderate cost
 - simple: “install and forget gear” !



- **traditional POCs only block local source’s lambda**

- different boxes for east and west terminals
- not suitable for multi-channel environments!

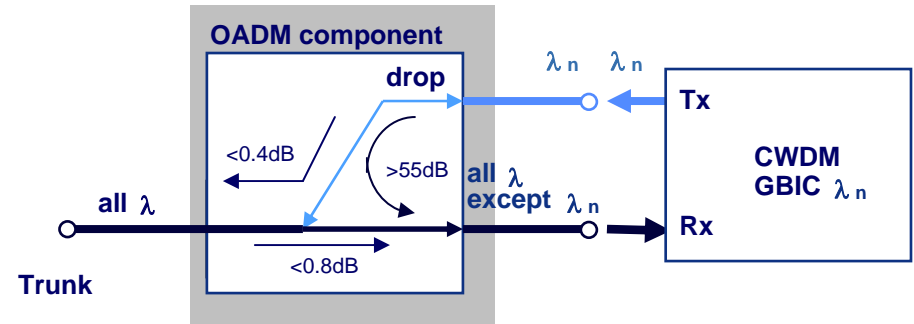

- **new style “flex” POCs use two internal OADMs and filter both Rx and TX ports of GBIC**

- much more flexible!
- same box east and west
- less noise at Rx
- allows daisy chaining
- slightly more loss
- slightly more co\$

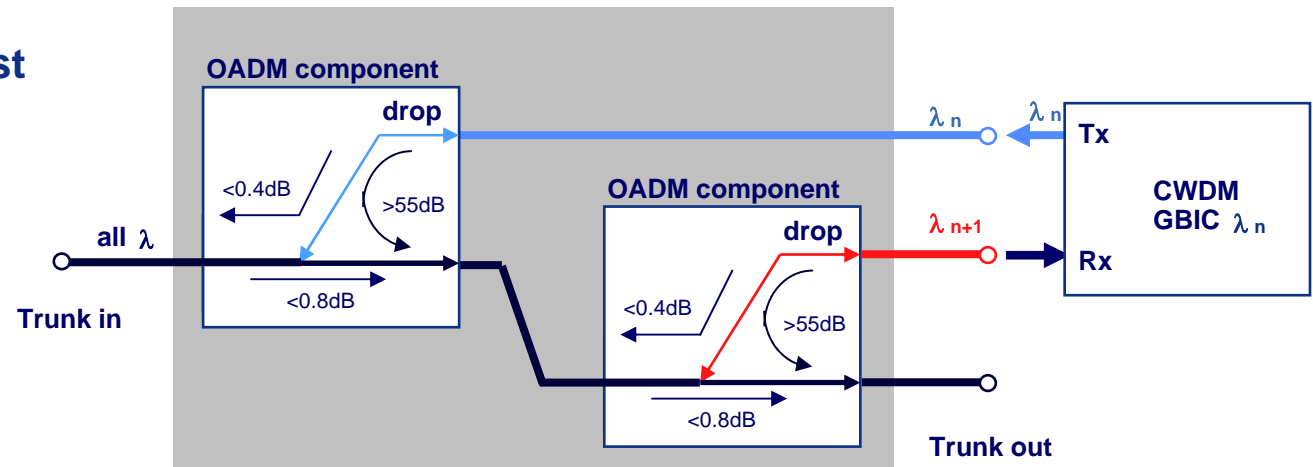

multi-channel GEs on a single fiber

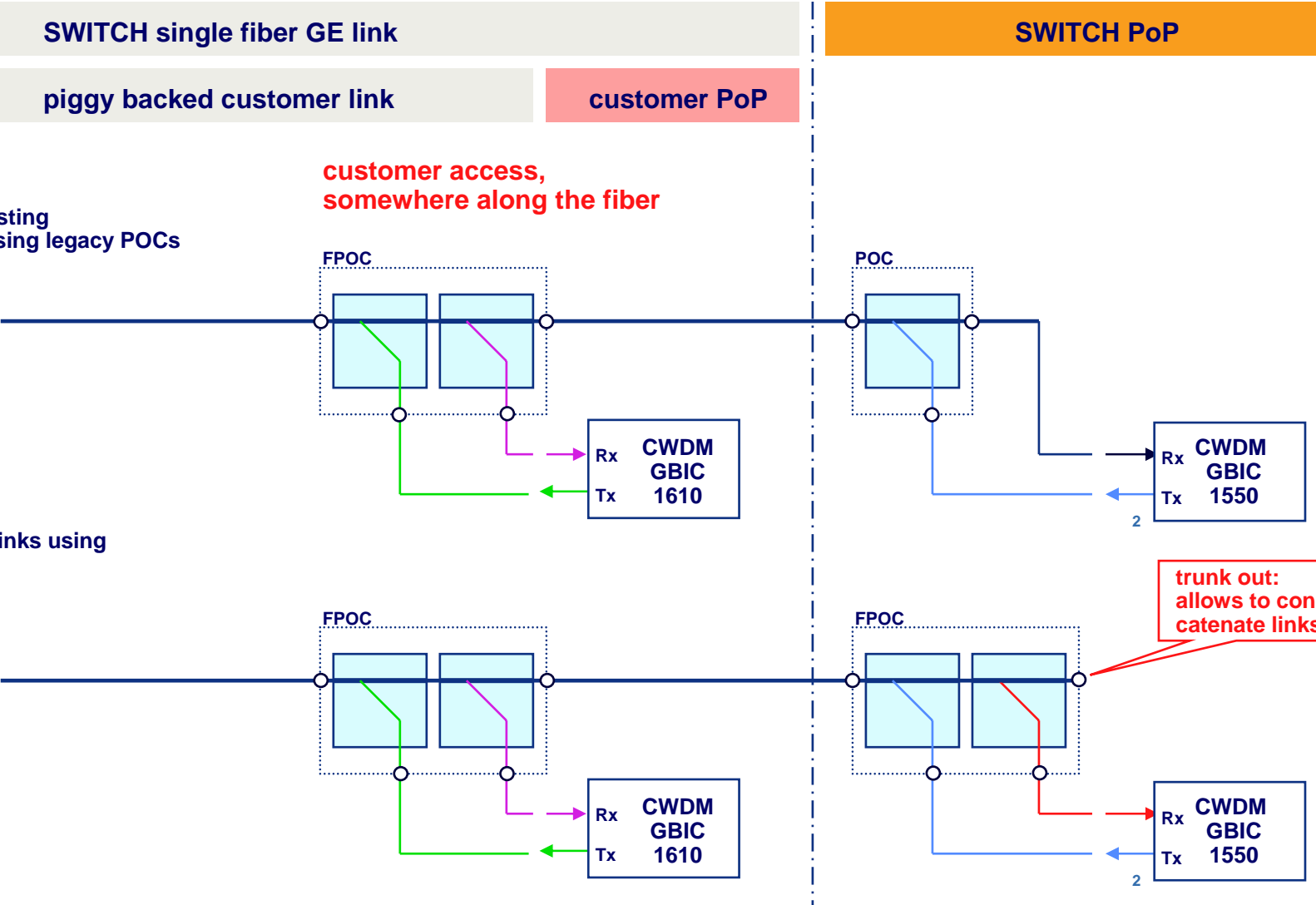

- **our standard color set for bi-directional Gigabit Ethernet links (“primary links”) is 1530/1550nm**
 - within EDFA range
 - allows amplified links up to 200km
- **when adding lambda tunnels on a fiber:**
 - use different color pairs
 - calculate with 4dB loss for the primary link per link added (this is the insertion loss of two flex POCs)
 - be OTDR-friendly!
 - carefully choose colors if links are long!

- **keep the OTDR window open!**
 - today's OTDRs specify a tolerance of $\pm 25\text{nm}$ for their 1550nm setting

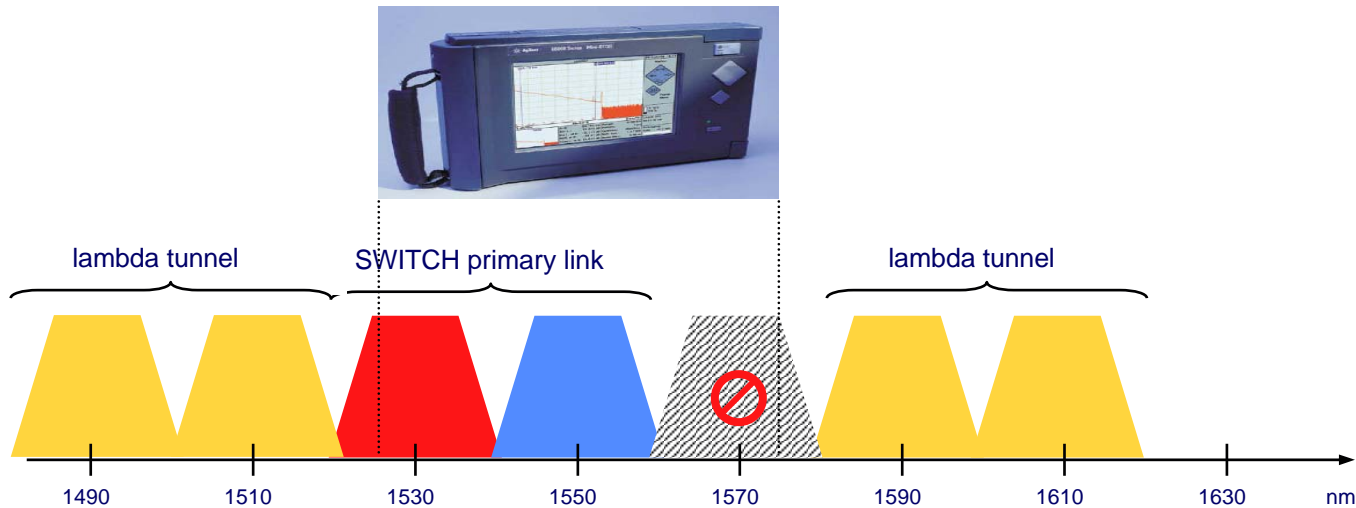

- **procedure to localize fiber breaks**
 - operator of primary link is responsible for the trunk fiber
 - only he can do a standard OTDR fiber break test without removing optical filters along the fiber

- quick lab test using an Anritsu OTDR

- two fiber spools of 25km SMF
- OTDR laser sending @1540nm
- 1530nm POC

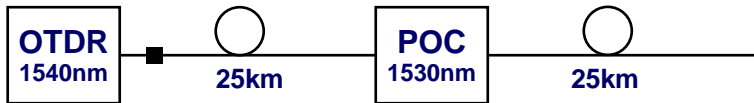
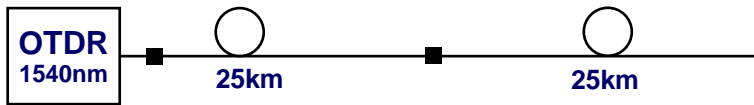

excess loss was ~0.4dB

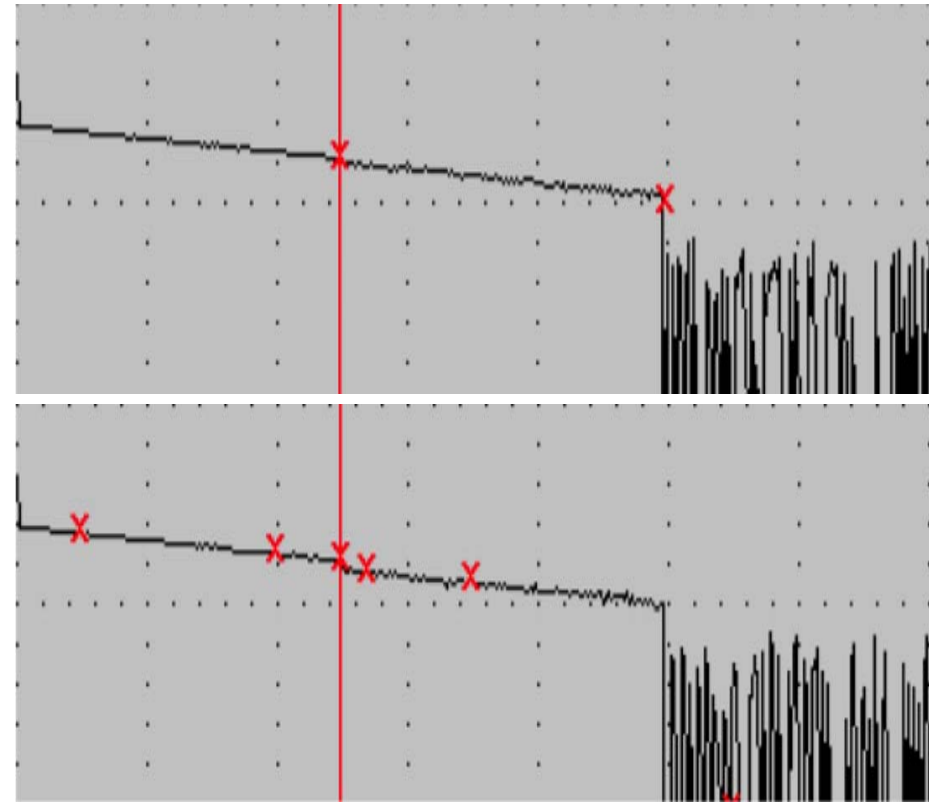

Which lambdas are best ?

- prefer lambdas with lowest attenuation!
 - attenuation depends on fiber type (which do not always know)
- based on data found on the web and from measurement data we conclude:
 - older G.652A fibers perform better in the upper CWDM channel range - let 1590 and 1610nm be our next best choice!
 - additional channels can be added by using lambdas below 1530nm, but attenuation might increase, depending on fibers used

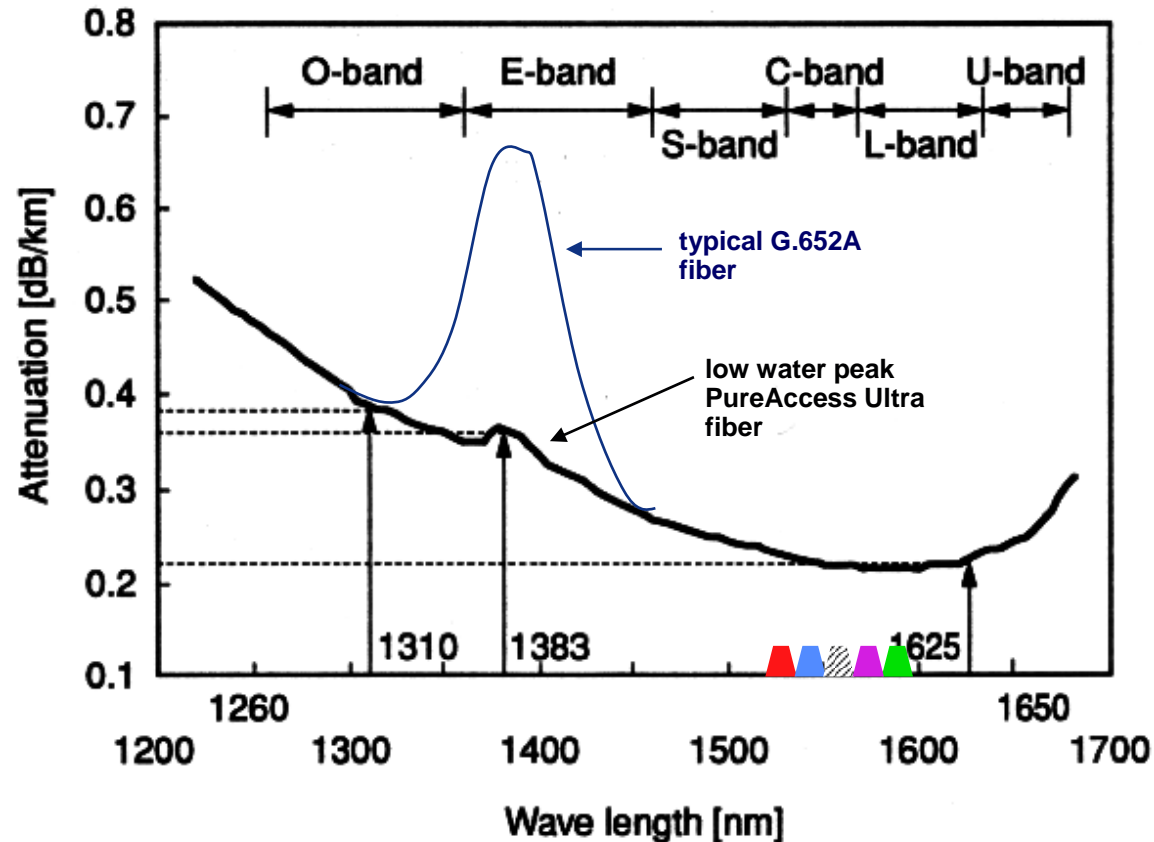

Our Lambda Tunnel Pilot

— existing SWITCHlambda fibers — existing VSnet fibers
— planned SWITCHlambda fibers

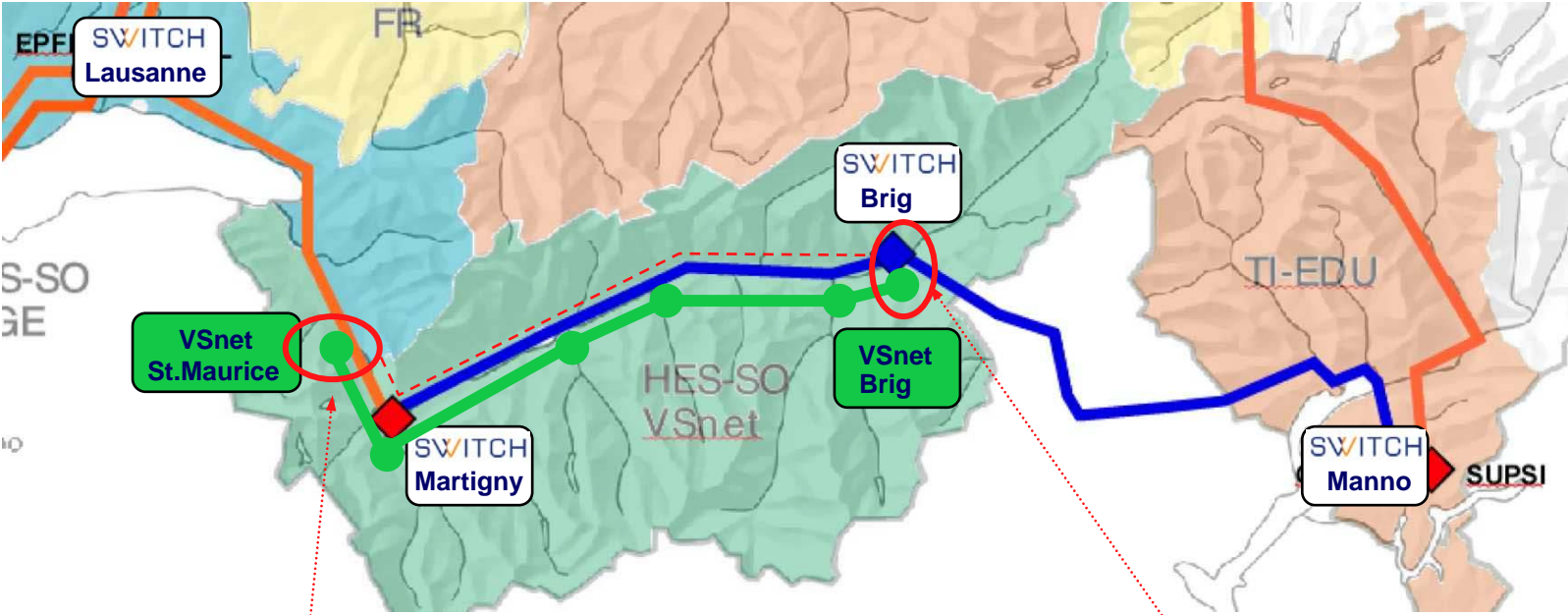

Proposed pilot project:
Establish a backup link between terminal nodes using a lambda tunnel through SWITCHlambda fibers

Lausanne - Brig Link using FPOC

operational responsibility

vsnet

SWITCH

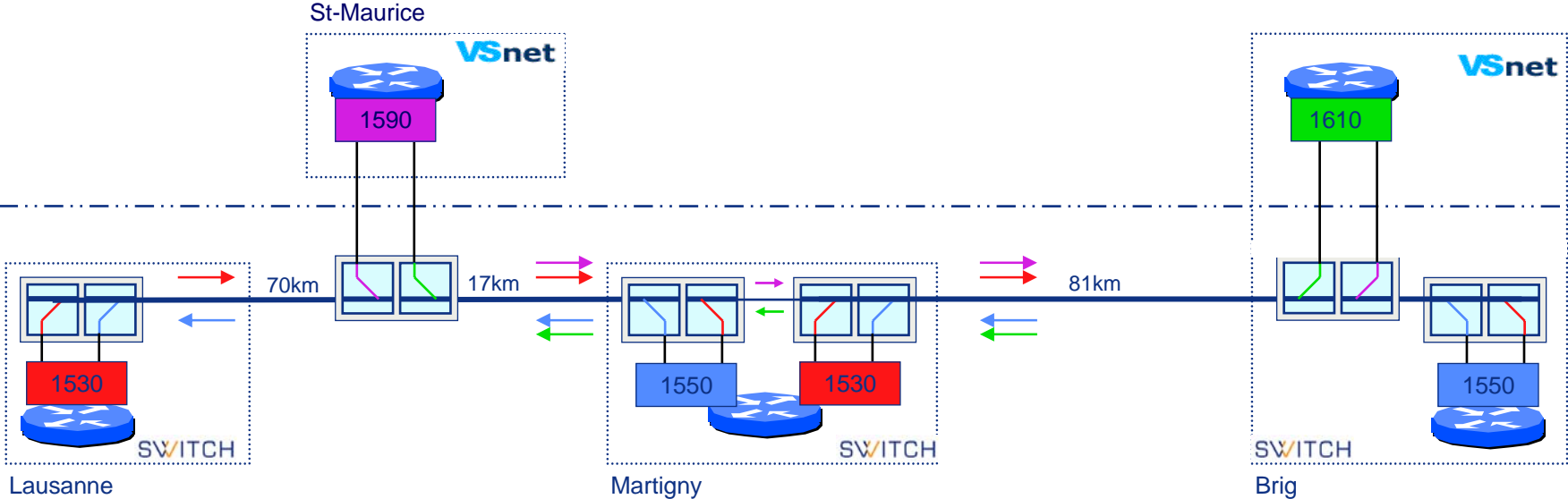

color scheme used:

- 1530 (Red arrow pointing right)
- 1550 (Blue arrow pointing left)
- 1590 (Purple arrow pointing right)
- 1610 (Green arrow pointing left)

- **fiber parameters, to be guaranteed by operator of trunk fiber:**
 - attenuation, including couplers
 - chromatic and polarization mode dispersion
 - max crosstalk from adjacent channels

- **parameters to be honored by customer:**
 - lambda range
 - max. permitted optical power
 - type of connectors

- **trunk fiber operator is responsible for**
 - uninterrupted trunk fiber
 - attenuation, chromatic and polarization mode dispersion within specs
 - OADMs working as specified
- **customer is responsible for**
 - overall design of his link
 - installation of active communication equipment in his PoPs
 - proper operation of his link, monitoring, failure recovery,...

caveats

- **customer has limited flexibility to debug fiber path on his own**
- **fault localization will be a joint effort of fiber operator and customer**

SWITCH plans to start a two year pilot project to get practical experience with this kind of infrastructure sharing

