

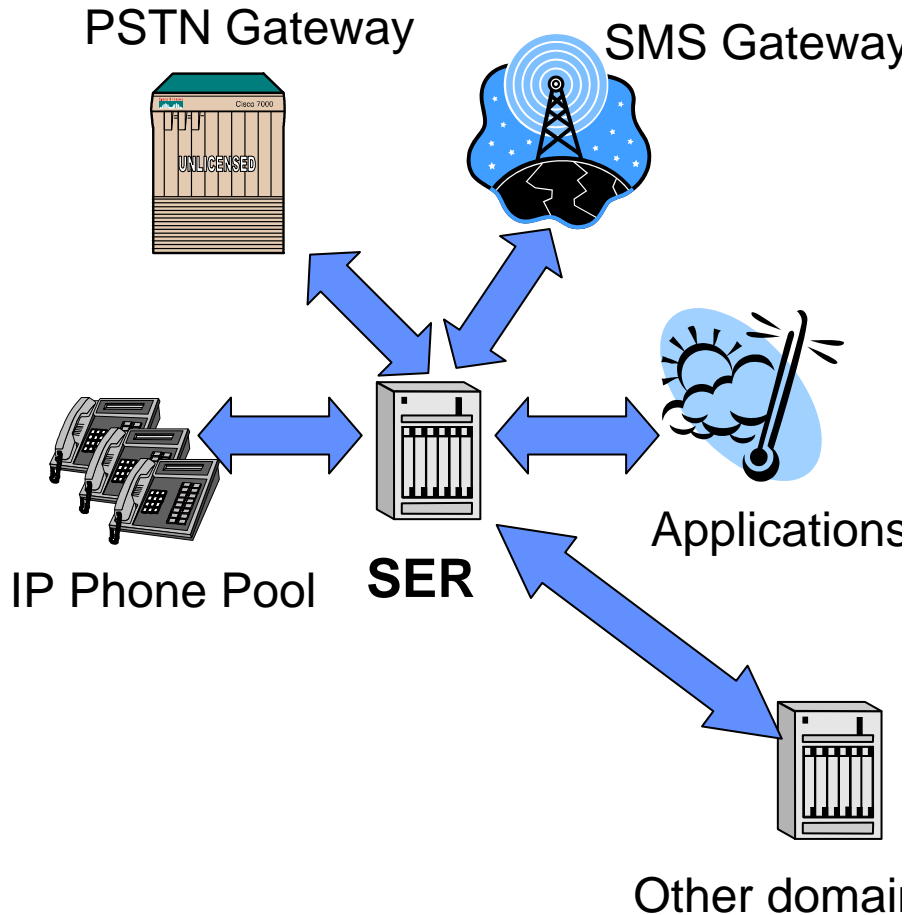

# SIP in IPv6 Networks

Rudolf Roth, Dorgham Sisalem, Reinhard Ruppelt  
Fraunhofer Fokus  
Berlin, Germany

# SIP Basics



- **SIP** (RFC 3261) core protocol for multimedia communications
- application-agnostic; mediating VoIP, instant messaging and presence, etc.
- resolving userIDs: *<user>@<domain>*
- Components:
  - User agent
    - Client: outgoing calls
    - Server: incoming calls
  - Proxy
  - Redirect
  - B2BUA (back-to-back UA)

# SIP Infrastructure



- [www.iptel.org](http://www.iptel.org)
- Implementation based on the SIP Express Platform:
  - SER SIP Express Router provides enhanced SIP functionalities with proxy, redirect, registrar and location management
  - SER Modules Toolbox: web-based mgmt interface, SMS gateway, accounting and authorization, server status monitoring, diagnostics utility

# SIP + IPv6

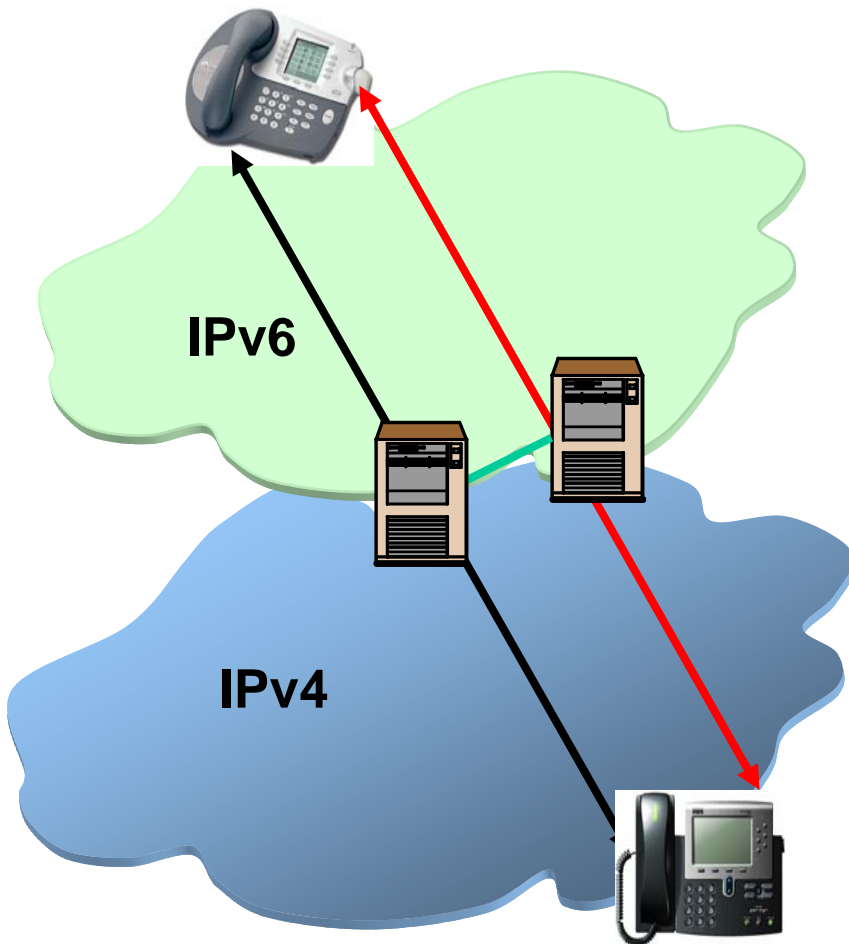

- SIP for IPv6
  - proxies and registrars capable of understanding IPv6 (SER)
  - IPv6 capable end applications (Kphone: KDE softphone)
  - Benefiting from IPv6 features: dynamic configuration, anycast
- SIP in heterogeneous IPv6/IPv4 environments
  - support for protocol translation
- work performed by FOKUS in IST 6net

# SIP in Heterogeneous Environments: SIP Protocol Translator Gateway

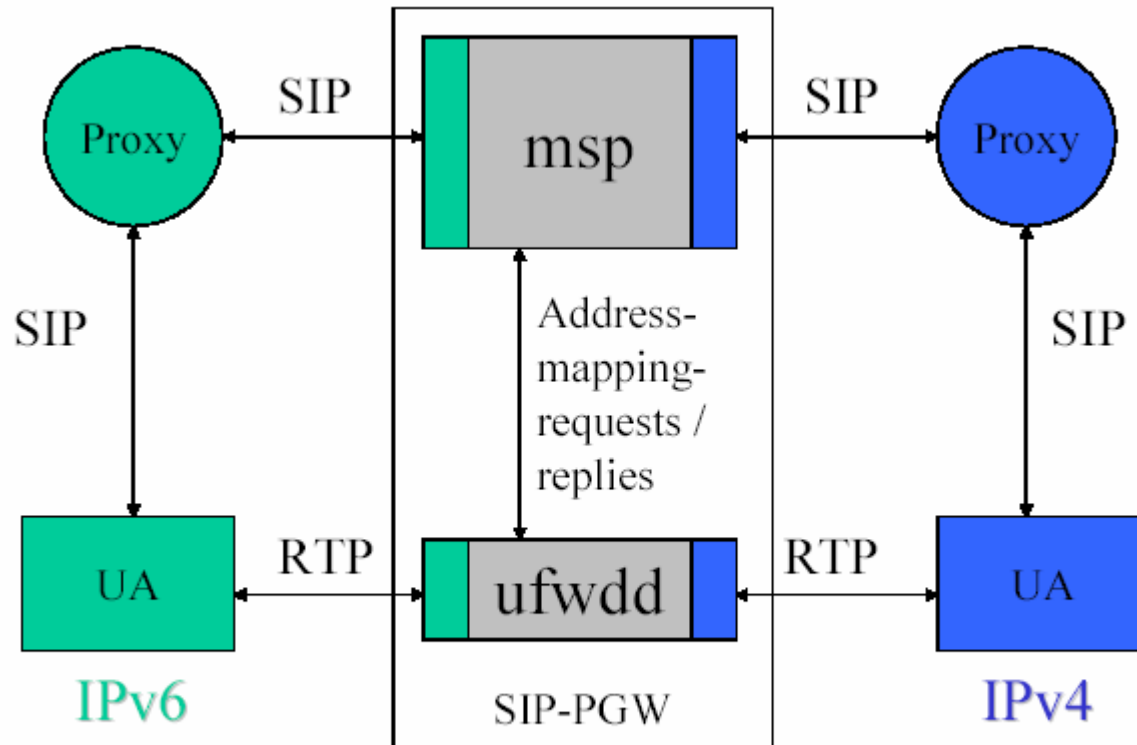
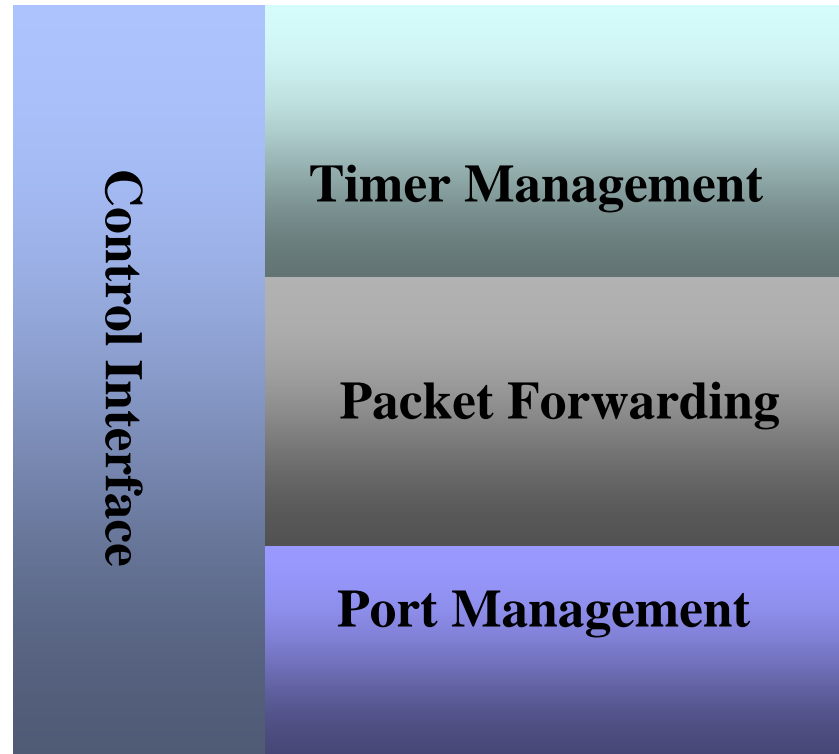

Figure 5 SIP gateway for heterogeneous environments (PGW)

- **Signaling translation: Mini SIP Proxy (msp)**
- **Media translation: UDP-forwarding daemon (ufwdd)**
- **Signaling-Media coordination**

# Media Translator

- Move UDP packets between IPv4 and IPv6 sockets
- Create/destroy the necessary ports for RTP and RTCP
- Administrate connection-timers for soft state
- Interact with the SIP proxy



# Mini-SIP Proxy

- Alter SIP headers
  - Adapt To, From, R-URI, Via, Record Route, Route
  - Adapt addresses in the SDP body
- Alter SDP parts (o, m, c)
- Proxy SIP messages
- Interaction with the media translator :
  - send map requests with terminal address & port
  - receive map result with proxy address & port in other protocol family

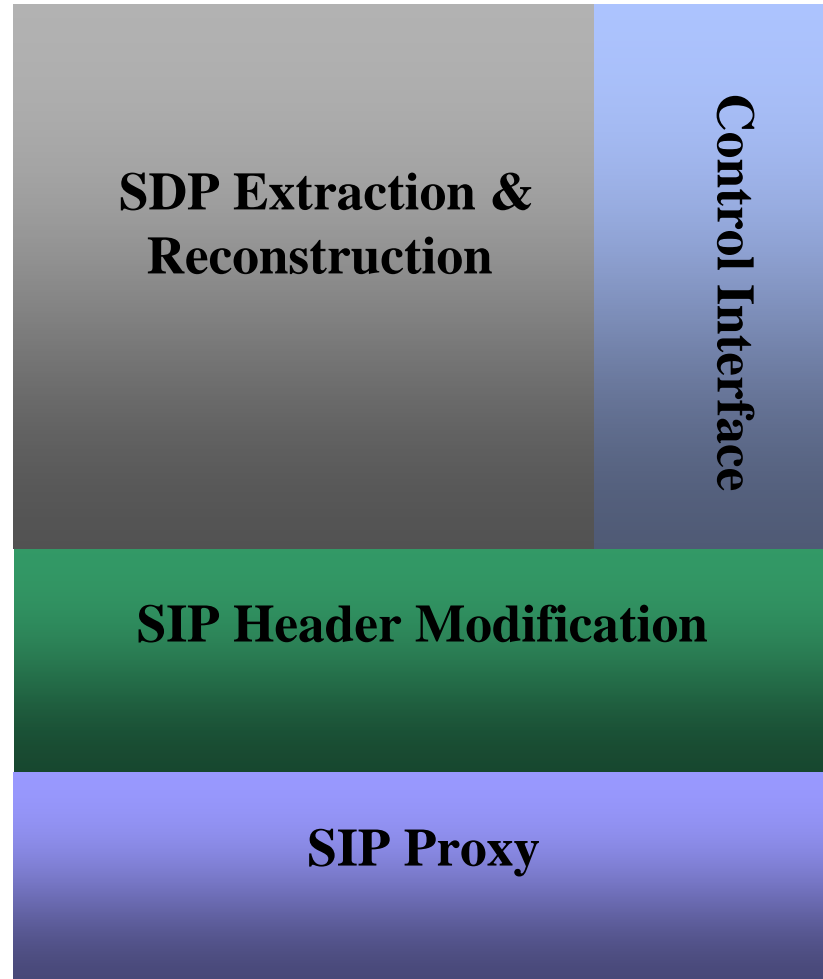

## [iptel.org SIP Software](#) >>

[SIP Express Router \(ser\)](#) **SIP Express Router (ser)**  
iptel.org's flagship:  
A high-performance, configurable SIP server: registrar, proxy or redirect server. It features an application-server interface, presence support, SMS gateway, SIMPLE2Jabber gateway, RADIUS/syslog accounting and authorization, server status monitoring, [FCP](#) security

[Ser Web](#) **Web-interface for administration and self-provisioning of [ser](#) users.**  
includes maintaining user profiles, admission control lists, sending instant messages, keeping track of calls made and missed, etc.

[SipSak](#) SipSak  
**Diagnostic and stress utility.**

[BonePhone UA](#) **A Linux SIP softphone.**  
Support for numerous codecs (bonephone utilizes rat). Phonebook.

[KPhone UA \(IPv6\)](#) **A Linux SIP softphone.**  
Linux KDE-3 based soft phone, supports IPv6.

[CPLEd](#) **A GUI-armed editor for CPL scripts.**  
A secure service creation environment.

[FCP Server](#) **Firewall/NAT Traversal Server.**  
Firewall control server allows



# References

- 6NET Deliverable D5.7: Report on Integration of SIP and IPv6  
[www.6net.org/publications/deliverables/D5.7.pdf](http://www.6net.org/publications/deliverables/D5.7.pdf)
- Home Page  
<http://iptel.org/>
- iptel.org Open Source SIP Software  
<http://iptel.org/products/>
- SER Module Documentation  
[http://iptel.org/ser/ser\\_modules.html](http://iptel.org/ser/ser_modules.html)
- Contact: [info@iptel.org](mailto:info@iptel.org)

The logo for iptel.org, featuring the text "iptel.org" in a light blue, lowercase, sans-serif font. The dots on the "i" and "o" are solid blue. The text is set against a light blue rounded rectangular background with a thin green horizontal line at the bottom.