



RENATER antispam service

EQUAL WS – Dec 9th 2009
Amsterdam

Jerome.Durand@renater.fr
Serge.Aumont@cru.fr





A bit of history

- Survey asking for antispam solutions deployed in the different sites of RENATER community (2008)
 - Showed that something indeed had to be done
- Anti-spam WG creation (sept 2008)
 - With good willing experts of RENATER community
 - State-of-the-art / Knowledge sharing
 - Pilot service (early 2009)
 - Tender preparation (April-May 2009)
 - Made it possible for GIP RENATER to learn the job and satisfy users need !
- Call for tenders (June-August 2009)
- Deployment (September 2009)
- Service opening (October 1st 2009)
- First friendly sites connected and first fixes (October-November 2009)
- Service in production mode (December 2009)



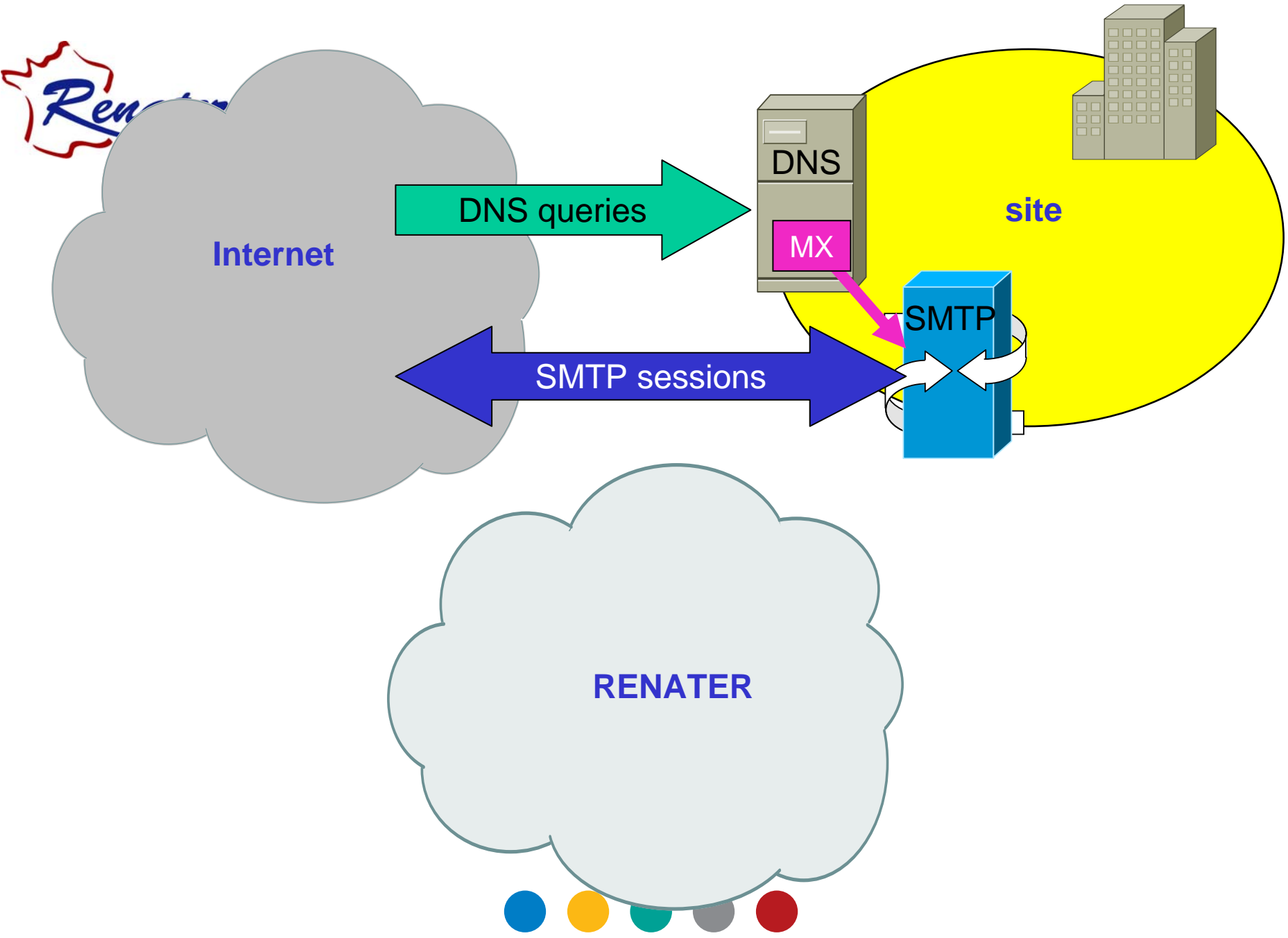

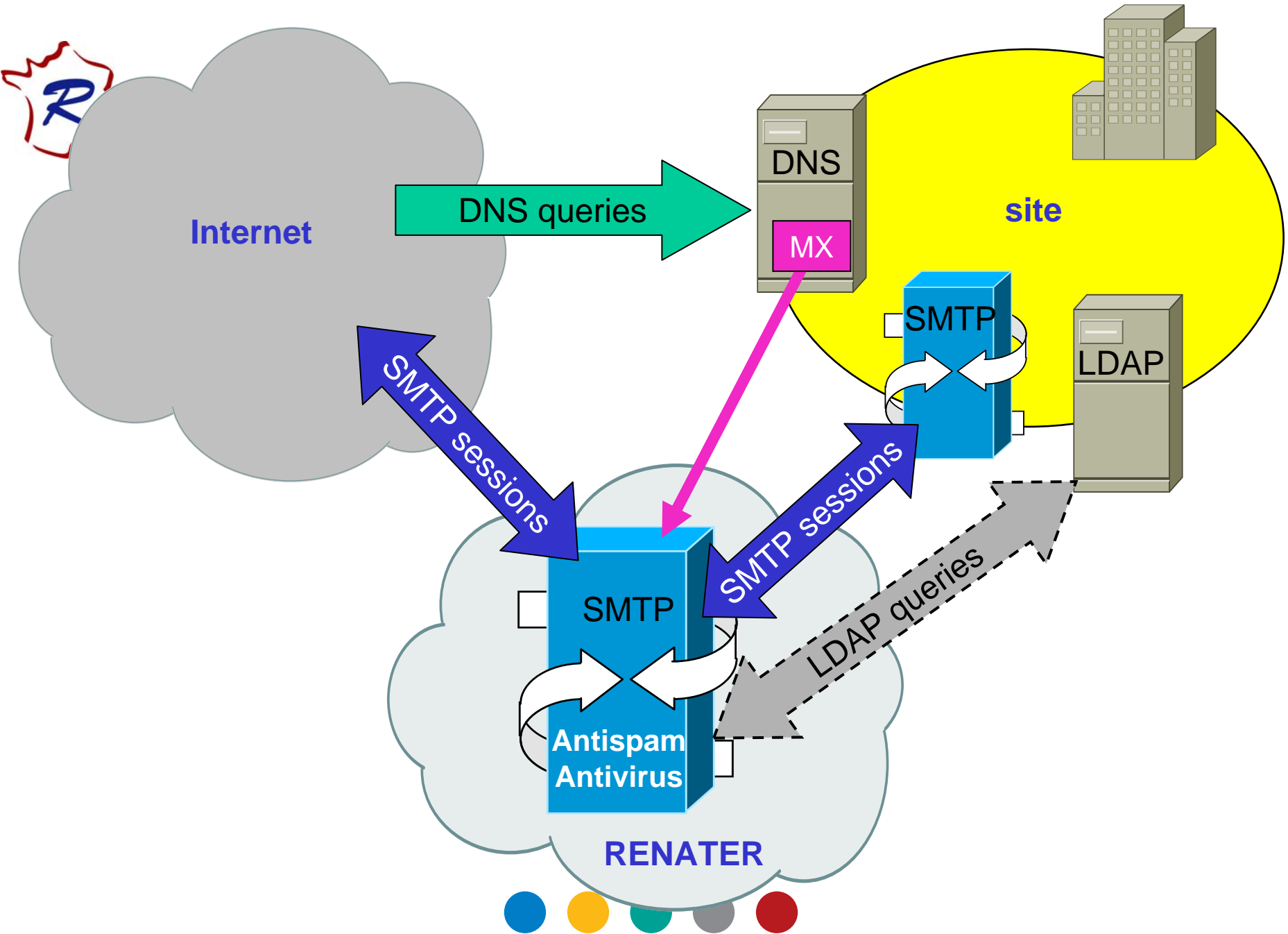



Solution

- Bizanga appliances (MTA's), with following components:
 - VadeRetro antispam
 - VadeRetro antivirus (heuristic analysis)
 - DocteurWeb antivirus (detections based on virus signatures)
- 2 appliances on 2 sites (HA)
- Up to 2 million mailboxes on this architecture
- Licences only for 500 000 boxes at this stage





Main characteristics

- Ingress SMTP only (at least for now)
- Antispam
 - Protocol filtering (connect/banner/helo-ehlo/mail-from/rcpt-to)
 - Filtering based on RBL (SpamHaus)
 - GL for dynamic domains and non-resolved IP's
 - SPF reject hard fails
 - ...
 - LDAP checks users are existing in domains (backscattering protection)
 - Content filtering
 - Huge amount of domains supported
 - Per domain logs
 - Rejects delayed until RCPT To
 - WL/BL can be global or per domain
 - At all layers
- Antivirus (optional)





Important

- An NREN is not an ISP !!!
- **Transparency**
 - We just can't drop the messages...
 - Transparency at every step of the email processing
 - Otherwise users won't trust the service
 - logging accessible directly by users
 - workflow will be accessible soon as well
- **Flexibility**
 - Users have some habits
 - We need to be able to adjust configuration
 - From simple tag in emails to black/white-lists
 - plans to develop a web portal for antispam configuration





Future

- Config web portal for user configuration
- RENATER community WL/BL ??
- IPv6
- Outgoing email filtering
- DKIM & domain reputation service
- Spam/Ham feedback



